

Design of Human Blood Type Detection Monitoring Device Based On Arduino Microcontroller

Susilo Susilo ^{a*}, Nova Irawati^b, Stepanus^b

^a *Departement of Electrical Engineering, Universitas Kristen Indonesia, Jakarta Indonesia*

^b *Departement of Electrical Engineering, Universitas Kristen Indonesia, Jakarta Indonesia*

^c *Departement of Electrical Engineering, Universitas Kristen Indonesia, Jakarta Indonesia*

* Corresponding author: Author name, Email: susilo.suwarno@uki.ac.id

Received: 15 Agustus 2025, Accepted: 10 Sept 2025, Published: 14 September 2025

KEYWORDS

Human Blood Type
Micro-Controller
Arduino
Light Dioda Resistor (LDR)
Antigent

ABSTRACT

The design of a monitoring tool to detect human blood type based on an Arduino micro-controller that will be displayed on Android is designed to automatically determine blood types A, B, AB and O and will be displayed via LCD and Android. This tool is designed considering the current rampant Covid-19 in Indonesia. Therefore, many patients need blood donors and do blood tests. So this tool is used effectively so that the medical team and donors do not have difficulty in conducting blood type tests or in carrying out blood transfusions. Knowing the properties of the human blood type detector is the purpose of this study. Blood types are identified using the blood type detector agglutination process, which occurs after the blood sample is dripped with "anti-sera" or antigens A, B, AB and Rh. This blood sample is then placed on a glass slide above the LDR. The micro-controller, which has been programmed to distinguish blood types, receives the data after that. A 16x2 LCD is used to display the results of the micro-controller after the database is activated and sent to the Android device.

1. Introduction

An electronic device called a blood type detector is used to test a person's blood type. This is usually done through a series of blood tests, including giving (Anti-sera A and B) which are then tested on object glasses and blood type cards.

To find out a person's blood type, so far experiments have been carried out and observations of the agglutination or non-agglutination reactions of red blood cells that have been exposed to Anti-sera fluid have only been carried out using the eyes.

Blood consists of many types of blood cells, which make up 45% of the blood. The number is in the range of 40 to 47 for hematocrit, which measures the volume of solid red blood cells. The remaining 55% is a yellowish liquid that forms a substance known as blood plasma. In essence, blood plasma is a dilute solution consisting of albumin, a substance that helps blood clotting, immunoglobulins (antibodies), hormones, and various proteins and ions.

According to Hastiningsih in 2016 "Determination of Blood Type in Humans Based on Arduino Uno" using a light sensor built using

an LDR (light dependent resistor). The tool can process blood type determination through a comparison of sensor outputs [1]

According to Dede Abduhrahman and Ade Heri Ganjar "Development of a Prototype of a Blood Type Test Tool with the ABO Method Using Arduino Mega" automatic blood type determination can be done using the ABO method using an LDR sensor as an indicator to determine blood type, especially if using a blood type test tool using Arduino Mega.

The purpose of making this tool is to facilitate the blood transfusion process. The design of the blood type detector consists of hardware and software. The components used in the design of the blood type detector are in the hardware, while the software section discusses the contents and structure of the program used in the design of the tool.

This blood type detector is made in the form of a box with a sensor placed on the side of the box. In order for the LED to illuminate the LDR, the LDR is placed on the lower side of the box above the LED. The photodiode and LED must fit in order to operate. So it is arranged at the end of the box at the bottom of the LDR there is a

blood sample to be detected. After that the Arduino program will automatically connect and will be displayed on Android in the Blynk application.

2. Materials and Methods

2.1 Experimental Materials

The materials used are Arduino Uno, 16x2 LCD, LDR sensor, and the components used will be integrated to read the prepared blood samples.

Furthermore, the tool is tested to ensure and see which components work well so that they can be compared with the reference tool. Furthermore, a comparative analysis is carried out on the tool made based on the reference, and to find out the accuracy value of the tool that has been tested. Regarding the collection of blood sample data, it is still done manually.

2.2 Experimental Methods

The collected experimental data is used to find, create, and evaluate the validity of the analysis. The design of this tool uses the experimental test research method and with qualitative and quantitative methods.

1. Descriptive approach for qualitative analysis of LDR sensor calibration data and system calibration.
2. Using a quantitative approach to describe the overall test results with a comparison of samples from blood type cards. And will start from identifying the needs required.

2.2.1 Sensor Test Data

The following data on sensor testing measurements with a certain distance can be seen in table 2.1 showing the results that the ABO group card can be read at a distance of 1 cm, 2 cm, 3 cm and 4 cm. while at a distance of 5 cm for blood group cards B and AB are not readable, because the blood sample on the card is not too much.

Table 1. Sensor Test Results with Certain Distance

No	Gol. Dar	Jarak				
		1 cm	2 cm	3 cm	4 cm	5 cm
1	A	Ya	Ya	Ya	Ya	Ya
2	A	Ya	Ya	Ya	Ya	Ya
3	B	Ya	Ya	Ya	Ya	Tidak
4	AB	Ya	Ya	Ya	Ya	Tidak
5	AB	Ya	Ya	Ya	Ya	Tidak
6	O	Ya	Ya	Ya	Ya	Ya
7	O	Ya	Ya	Ya	Ya	Ya
Persentase		100%	100%	100%	100%	70%

2.3 Overall Tool Visualization

At this stage, a Human Blood Type Detection Tool Design and Construction Circuit will be

designed based on the Arduino Uno Microcontroller with an Android Display, with 16x2 LCD output, LED and LDR. And the schematic diagram shown in figure 1.

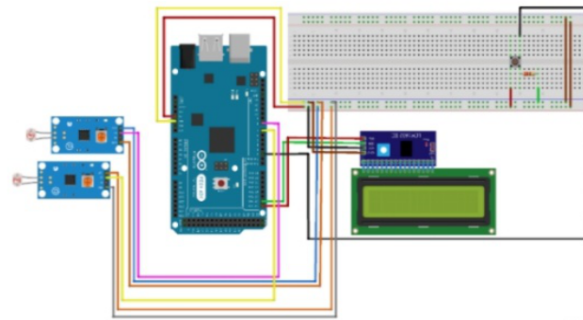

Figure 1. Schematic Diagram Tool



Figure 2. Blood Type Measurement Device

The process of connecting cables to components is shown in the following table:

Table 2. Communication Device Pin Interconnection

Arduino Uno	LCD (Liquid Crystal Display)	Sensor LDR (Light Dependent Resistor)
Pin GND	Pin GND	Pin GND
Pin 5V	Pin VCC	Pin VCC
Pin SDA	Pin SDA	-
Pin SCL	Pin SCL	-
Pin A0	-	Pin D0

3. Results and Discussion

3.1. Processing Current and Resistance Test Data

The table below shows the data from the current and resistance measurements on blood types that were given serum and tested with a blood type detector:

Table 3. Blood Type A Sample

Antigen	Anti A	Anti B	Anti AB	Anti RH

Resistance (mOhm)	388-412	371-416	404-436	354-411
Ampere (I)	0,008398-0,008917	0,008317-0,009326	0,007935-0,008564	0,008418-0,009774

Table 4. Blood Type B Sample

Antigen	Anti A	Anti B	Anti AB	Anti RH
Resistance (mOhm)	431-467	403-439	422-457	390-414
Ampere (I)	0,007408-0,008027	0,007881-0,008585	0,007571-0,008199	0,008357-0,008871

Table 5. Blood Type AB Sample

Antigen	Anti A	Anti B	Anti AB	Anti RH
Resistance (mOhm)	358-391	356-395	345-407	375-429
Ampere (I)	0,008849-0,009664	0,008759-0,009719	0,008501-0,010028	0,008065-0,009226

Table 6. Blood Type O Sample

Antigen	Anti A	Anti B	Anti AB	Anti RH
Resistance (mOhm)	440-469	421-473	450-490	388-410
Ampere (I)	0,007377-0,007863	0,007315-0,008218	0,007061-0,007688	0,008439-0,008917

3.1.2. Data Analysis of Maximum (Max) and Minimum (Min) Resistance Values

The following shows the maximum and minimum values of the resistance measurements along with a graph percentage level, with the following analysis:

Table 6. Minimum Resistance Value

Blood Type	Anti A	Anti B	Anti AB	Anti RH
	Anti A	Anti B	Anti AB	Anti RH
A	391	397	371	343
B	431	403	422	390
AB	335	356	345	375
O	442	421	439	388

Table 7. Maximum Resistance Value

Blood Type	Anti A	Anti B	Anti AB	Anti RH
	Anti A	Anti B	Anti AB	Anti RH
A	426	428	428	407
B	467	439	457	414
AB	372	419	388	421
O	481	461	493	407

From the maximum and minimum data obtained, it can be seen that the resistance of each blood type can change because it is influenced by the LDR sensor that is exposed to and blocked by room/environment light.

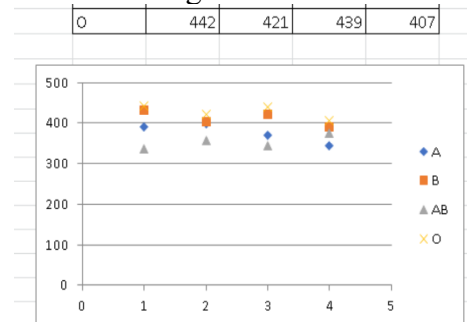

Figure 3. Maximum Value scattering

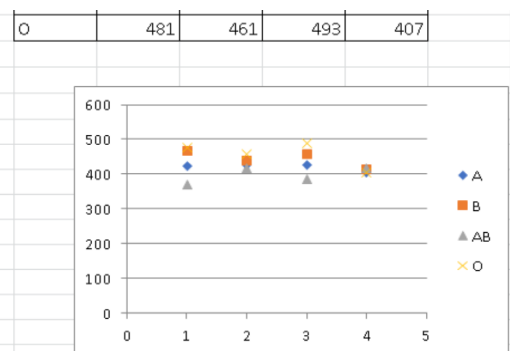

Figure 4. Maximum Value scattering

From the data obtained according to figure 3 and 4, it can be found that several errors were found when detecting blood type, including:

- Not enough blood was dripped on the blood type card so that the blood clot did not cover the entire LDR sensor

- b) Incorrect placement of the blood type card so that the results obtained were invalid
- c) The difference in resistance in detecting blood type was very close.

3.1.3. Error Level Analysis

Errors that occur in the form of numbers are as follows:

1. For blood type A

$$\text{Error rate} = (2/10) \times 100\% = 10\%$$

2. For blood type B

$$\text{Error rate} = (0/10) \times 100\% = 0\%$$

3. For AB blood type

$$\text{Error rate} = (2/10) \times 100\% = 20\%$$

4. For blood type O

$$\text{Error rate} = (1/10) \times 100\% = 10\%$$

3.1.4. Success Rate Analysis

Based on the data obtained, the success rate of data errors for each blood type can be calculated:

- a) Blood type A error rate = 10%
- b) Blood type B error rate = 0%
- c) Blood type O error rate = 20%
- d) Blood type AB error rate = 10%

$$\begin{aligned} \text{Success rate} &= 100\% - (10\% + 0\% + 20\% + 10\%) \\ &= 100\% - 40\% = 60\% \end{aligned}$$

It can be said that the human blood type detector has a success rate of 60%.

4. Conclusion

Based on the results of the measurement data processing and further analysis, the following conclusions can be drawn:

- a) Blood types A, B, AB and O are divided into four categories based on the types of antigens and antibodies in the type.
- b) Blood type +Anti-A is determined whether it clots and blood +Anti-B does not clot. Blood type B is determined whether blood +Anti-B does not clot. And if blood +Anti-A does not clot and blood +Anti-B does not clot, then the blood type is O.
- c) By using a chemical reaction on a blood sample that has been given a reagent, the LDR sensor detects light. Depending on the settings in the Arduino software, the detected light can identify the type of blood type.

- d) The resistance value in this final assignment can increase and decrease automatically depending on the LDR sensor exposed to light.
- e) From the results of the design, testing and analysis, it can be concluded that the application works well with additional features that help.

5. References

- [1] W. Tegegne, T. Tesfaye, Y. Zeleke, and G. Ketema, "Title in sentence case", *Discov. Mater.*, vol. 2, no. 1, p. 14, 2022, doi: 10.1007/s43939-022-00034-2.
- [1]. Melati, Emaria, et al. (2011), "*Desain dan pembuatan alat pendeteksi golongan darah menggunakan mikrokontroler*". *Jurnal Sistem Komputer Universitas Sriwijaya*.
- [2]. Muis, Saludin. 2013. "*Prinsip Kerja LCD dan Pembuatannya*." Universitas Islam Nusantara: Graha Mulia.
- [3]. Siahaan, Haslena A. 2017. *tingkat intensitas cahaya dengan menggunakan sensor LDR berbasis arduino uno R3* [Skripsi]. Medan: Universitas Sumatera Utara, Program Sarjana.
- [4]. Izzah Fadhilah Akmaliah, N. A. (2011). *Alat Pendeteksi Golongan Darah Manusia Berbasis Mikrokontroler 89s51*. Snatika 2011, Issn 2089-1083.
- [5]. Landstainer K, Wiener A.S,"*An Agglutinable factor in human blood recognized immune sera for rhesus blood*" *Proc. Soc Exp Biol Med*; 43,223-224 ,1940.
- [6]. Irianto, Koes. 2014. *Panduan Lengkap Biologi Reproduksi Manusia Human Reproductive Biology Untuk Paramedis Dan Nonmedis*. Bandung: Alfabeta.
- [7]. Sujadi, Harun, And Tomi Yendra. "*Rancang Bangun Sistem Pengukur Tinggi Badan Otomatis Menggunakan Microcontroller Arduino Uno R3 Dan Sensor Ultrasonic Hcsr04 Berbasis Android*." *Seminar Nasional Teknologi Informasi*. Vol. 1. 2018.
- [8]. Ridha, W. M., & Priyatman, H. (2019). "*PERANCANGAN PENDETEKSI GOLONGAN DARAH BERBASIS ARDUINO UNO DENGAN SISTEM ABO*." *Jurnal Teknik Elektro Universitas Tanjungpura*.
- [11]. Denny Darlis, Aris Hartaman , Septiana Dwika Pangestu 2020 "*Smartphone Application of Blood Type Detection using Image Classifier Method*".